

HÄFELE
FUNCTIONALITY FOR YOU



 **KESSEBÖHMER**
—exclusively by **HÄFELE**

CONVOY
centro

www.hafele.co.id

CONVOY makes dreams come true

With CONVOY, we have worked systematically to take the design of food storage units to a new level. One glance makes this evident: the streamlined trays seem to float effortlessly. They offer more usable space and excellent visibility. If preferred, trays can be supplied without side railings, making it even easier to retrieve items and to use the available vertical space. The look is streamlined with straight lines predominating. It opens up almost infinite prospects for customisation. You'll be amazed to see how many innovations fit into one storage unit...



Mixed double: Fridge and larder unit

One gentle pull slides the entire contents out in front of the unit – for a clear view from either side and very fast access. It makes kitchen work much easier, it saves time and effort and it effectively avoids the risk of items being forgotten at the back of a cupboard. Combining a refrigerator with a CONVOY unit creates a storage centre in a modern fitted kitchen. **And it's available 24/7.**



“ Owners of larder units are proud of being ‘well-organised’. No wonder: all groceries are stored centrally in one spacious pull-out unit in the kitchen ”

A clear view and complete transparency

Shelf-type storage

There are many reasons for choosing CONVOY

- Top runner concealed by the tray. New-design runner connections mean more choice with fewer variants.
- Easier loading and unloading.
- Easy, stepless height adjustment for the trays – no tools required.
- 80 kg load capacity. All the groceries can be stored in just one unit.
- Quiet – damping is standard. The automatic closing mechanism has been optimised for CONVOY. The silent storage unit!
- Improved smooth action. A new runner system ensures CONVOY glides even more softly out of the cabinet.

Individually height adjustable shelves



Easier loading and unloading.

Minimalistic design and cantilevered "floating" trays – with the new single-tube frame



Fast precision adjustment!



Synchronisation with a toothed rack guarantees 100% reliability

The broad runner makes for even smoother action

If there's nothing left to wish for,
That's Perfection



Larder unit front extension CONVOY

Full extension with soft extension and closing mechanisms

- **Material** Hanging profile, front brackets, extension fitting and railing: steel, shelf: chipboard.
- **Finish** Hanging profile and front brackets: plastic coated white aluminium, RAL 9006, extension fitting: aluminium coloured, shelf: white.
- **For cabinet width** 450 mm.
- **Load bearing capacity** 80 kg load.
- **Version** Shelves with height extension panels and nonslip effect, top shelf conceals the runner, further shelves continuously height adjustable.
- **Internal cabinet depth** ≥500 mm.
- **Side panel thickness** 16 or 19 mm.

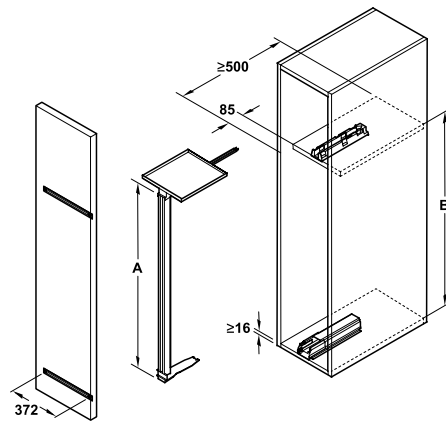

Internal cabinet height mm	Dim. A mm	Dim. B mm	Number of trays	Cat. No.
1100 - 1200	730	767	4	545.81.014
1900 - 2000	1530	1567	5	545.81.084
2100 - 2200	1730	1767	6	545.81.114

Packing: 1 set

Supplied with

- Hanging profile with front fixing (1 set)
- Extension runner (1 pc)
- Front brackets (2 pc)
- Top shelf with Integrated runner and accessories (1 set)
- Front stabiliser



www.hafele.co.id

Häfele offices & showrooms

Head Office: Taman Tekno BSD Blok A No 3 Serpong, Tangerang 15314, P +62 21 7587 8888, F +62 21 7587 7777, info@hafele.co.id

Central Java: Jl. Majapahit 91 Ruko D, Semarang 50167, P +62 24 767 444 66, F +62 24 767 444 33, smg@hafele.co.id

Yogyakarta: Jl. Wonosari, Ruko Tandan Raya B6 Yogyakarta 55198, P +62 274 451 660, F +62 274 451 660, yogya@hafele.co.id

East Java: Jl. Mayjend Sungkono 176-178 Ruko Grand Sungkono Blok A8 Surabaya 60189, P +62 31 5680800, F +62 31 5670800, sby@hafele.co.id

Bali: Jl. Bypass Ngurah Rai 120 i Kuta 80361, P +62 361 764 278, F +62 361 759 995, dpr@hafele.co.id